



# Installation and Operation Instructions Z3S

## MATRIX® Compatible Z3™ Siren

**IMPORTANT!** Read all instructions before installing and using. Installer: This manual must be delivered to the end user.



**WARNING!**

Failure to install or use this product according to manufacturer's recommendations may result in property damage, serious injury, and/or death to those you are seeking to protect!

 **Do not install and/or operate this safety product unless you have read and understood the safety information contained in this manual.**

1. Proper installation combined with operator training in the use, care, and maintenance of emergency warning devices are essential to ensure the safety of emergency personnel and the public.
2. Emergency warning devices often require high electrical voltages and/or currents. Exercise caution when working with live electrical connections.
3. This product must be properly grounded. Inadequate grounding and/or shorting of electrical connections can cause high current arcing, which can cause personal injury and/or severe vehicle damage, including fire.
4. Proper placement and installation is vital to the performance of this warning device. Install this product so that output performance of the system is maximized and the controls are placed within convenient reach of the operator so that they can operate the system without losing eye contact with the roadway.
5. It is the responsibility of the vehicle operator to ensure daily that all features of this product work correctly. In use, the vehicle operator should ensure the projection of the warning signal is not blocked by vehicle components (i.e., open trunks or compartment doors), people, vehicles or other obstructions.
6. The use of this or any other warning device does not ensure all drivers can or will observe or react to an emergency warning signal. Never take the right-of-way for granted. It is the vehicle operator's responsibility to be sure they can proceed safely before entering an intersection, drive against traffic, respond at a high rate of speed, or walk on or around traffic lanes.
7. This equipment is intended for use by authorized personnel only. The user is responsible for understanding and obeying all laws regarding emergency warning devices. Therefore, the user should check all applicable city, state, and federal laws and regulations. The manufacturer assumes no liability for any loss resulting from the use of this warning device.

### Specifications:

<b>Size:</b>	Control Head (HxLxD)	3.25" x 6.75" x 1.30"
	Amp (HxLxD)	3.25" x 10.50" x 6.75"

<b>Weight:</b>	Amplifier	7.6 lbs
	Control Head	0.6 lbs

<b>Input Voltage:</b>	12 VDC Nominal 10-18 VDC Max
-----------------------	---------------------------------

<b>Input Current:</b>	Amplifier	100W: 8.5A
		200W: 17.0A
		300W: 25.5A

<b>Auxiliary Outputs:</b>	Aux A (High Current)	20A each	25A Total
	Aux B (Mid Current)	10A each	25A Total
	Aux C (Digital)	0.5A each	

<b>Temp. Range:</b>	-40°F to 149°F (-40°C to 65°C)
---------------------	-----------------------------------



**WARNING!**

Sirens produce loud sounds that may damage hearing.



- Wear hearing protection when testing
- Use siren only for emergency response
- Roll up windows when siren is operating
- Avoid exposure to the siren sound outside of vehicle

## Unpacking and Pre-Installation:

Carefully remove the product and place it on a flat surface. Examine the unit for transit damage and locate all parts. If damage is found or parts are missing, contact the transit company or Code 3. Do not use damaged or broken parts.

Ensure the product voltage is compatible with the planned installation.

**!** Sirens are an integral part of an effective audio/visual emergency warning system. However, sirens are only short range secondary warning devices. The use of a siren does not insure that all drivers can or will observe or react to an emergency warning signal, particularly at long distances or when either vehicle is traveling at a high rate of speed. Sirens should only be used in a combination with effective warning lights and never relied upon as a sole warning signal. Never take the right of way for granted. It is the vehicle operator's responsibility to be sure they can proceed safely before entering an intersection driving against traffic, or responding at a high rate of speed. The effectiveness of this warning device is highly dependent upon correct mounting and wiring. Read and follow the manufacturer's instructions before installing this device. The vehicle operator should check the equipment daily to insure that all features of the device operate correctly.

To be effective, sirens must produce high sound levels that potentially can inflict hearing damage. Installers should be warned to wear hearing protection, clear bystanders from the area and not to operate the siren indoors during testing. Vehicle operators and occupants should assess their exposure to siren noise and determine what steps, such as consultation with professionals or use of hearing protection should be implemented to protect their hearing.

This equipment is intended for use by authorized personnel only. It is the user's responsibility to understand and obey all laws regarding emergency warning devices. The user should check all applicable city, state and federal laws and regulations. Code 3, Inc., assumes no liability for any loss resulting from the use of this warning device.

Proper installation is vital to the performance of the siren and the safe operation of the emergency vehicle. It is important to recognize that the operator of the emergency vehicle is under psychological and physiological stress caused by the emergency situation. The siren system should be installed in such a manner as to: A) Not reduce the acoustical performance of the system, B) Limit as much as practical the noise level in the passenger compartment of the vehicle, C) Place the controls within convenient reach of the operator so that he can operate the system without losing eye contact with the roadway.

Emergency warning devices often require high electrical voltages and/or currents. Properly protect and use caution around live electrical connections. Grounding or shorting of electrical connections can cause high current arcing, which can cause personal injury and/or severe vehicle damage, including fire.

**PROPER INSTALLATION COMBINED WITH OPERATOR TRAINING IN THE PROPER USE OF EMERGENCY WARNING DEVICES IS ESSENTIAL TO INSURE THE SAFETY OF EMERGENCY PERSONNEL AND THE PUBLIC.**

## Installation and Mounting:

**IMPORTANT!** This unit is a safety device and it must be connected to its own separate, fused power point to assure its continued operation should any other electrical accessory fail.

**!** **CAUTION!** When drilling into any vehicle surface, make sure that the area is free from any electrical wires, fuel lines, vehicle upholstery, etc. that could be damaged.

The Z3S Siren Control Head, shown in Figure 1, is designed to mount directly into the console of most leading manufacturers. It may also be mounted above the dash, below the dash or on the transmission tunnel using the mounting hardware supplied (see Figure 2). Ease of operation and convenience to the operator should be the prime consideration when choosing a mounting location. However, the user must also consider the deployment area for the air bag of the vehicle and other factors which might impact the safety of the vehicle occupants. When connecting a CAT5 cable or Microphone to the back of the Z3S Siren Control Head, use tie wraps, as shown in Figure 3, to relieve strain on the wires.

The Z3S Amplifier is mounted with four screws (not supplied). Mount the Z3S Amplifier so that connectors and wiring are easy to access.

**NOTE: All Z3S equipment should be mounted in locations that are safe from moisture. All wiring should be routed so that it cannot be damaged by sharp edges or moving parts.**



**Figure 1**

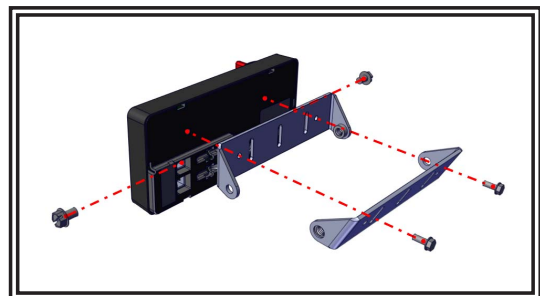

**Figure 2**

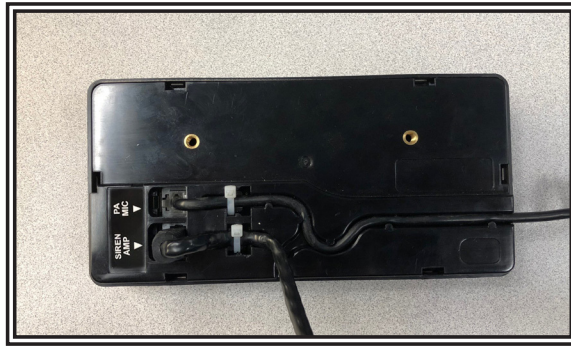

**Figure 3**

**Wiring Instructions:**

The Z3S Siren acts as a central node on the Matrix network, and provides a USB interface for system configurability via PC.

All other Matrix compatible products can connect to the Z3S Siren using one or more of the four provided connections, labeled AUX4, CANP\_CANN, PRI-1, and SEC-2. For example, a Matrix compatible serial lightbar can connect to the PRI-1 port with a CAT5 cable.

**NOTE: the PRI-1 port must be utilized first, before additional products can be connected to the SEC-2 port.**

See Wiring Diagram for the details of each harness. Connect each harness from the siren to the equipment to be controlled using proper crimping techniques and adequate wire gauges. The USB port can be used to connect the siren to a computer running the MATRIX® CONFIGURATOR.

**Caution!! Do not connect anything other than a 100 watt speaker to the siren speaker outputs. This will void the siren and/or speaker warranty!**

**Power Distribution:**

Connect the red (power) and black (ground) wires from the 690-0724-00 Power Harness to a nominal 12 VDC supply, along with three (3) customer supplied in-line, slow blow ATC style fuses. Use one for each red (power) wire. Each fuse must be rated for 30A. Please note that the fuse holders selected by the customer must also be rated by the manufacturer to meet or exceed the corresponding fuse ampacity. See the wiring diagram for details.

The Aux A Outputs are High Current; they can supply a maximum of 20A each or 25A combined. The Aux B Outputs are Mid Current; they can supply a maximum of 10A each. The Aux C Outputs are Digital; they can supply a maximum of 0.5A each and be configured for either *Positive* or *Ground* output. The Aux B and Aux C Outputs can supply up to 25A combined.

**NOTE: Any electronic device may create or be affected by electromagnetic interference. After installation of any electronic device, operate all equipment simultaneously to insure that operation is free of interference.**

Output Loads	
A*	20 amps
B*	10 amps
C	0.5 amps

\*Flashable configurable outputs

# Wiring Diagram:

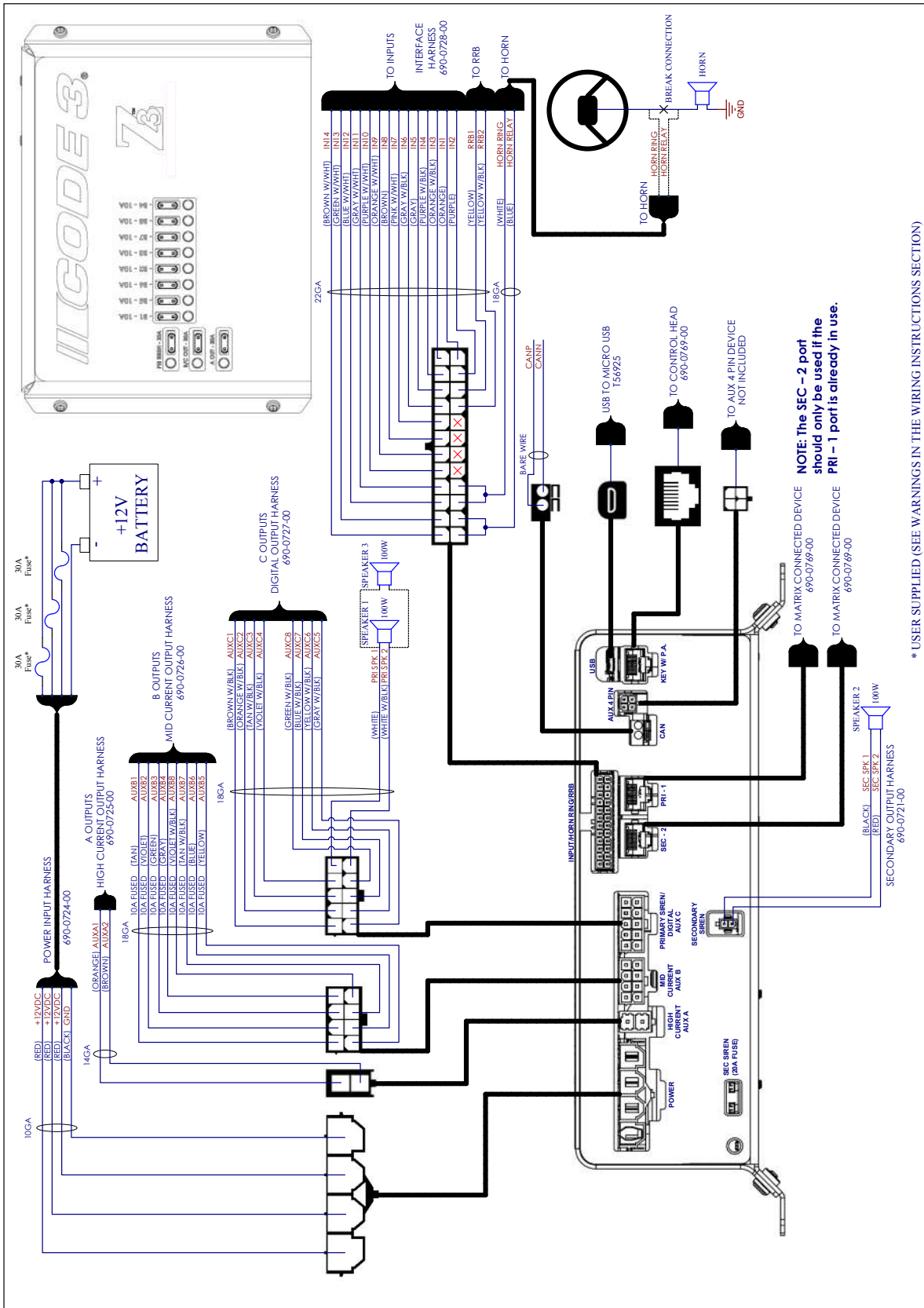

**Device Functionality:**

<b>Control Head - Default Functions</b>			
<b>Input</b>	<b>Type</b>	<b>Function</b>	<b>Network</b>
Slide/Alert 0	Toggle	Tones OFF	Alert 0
Slide/Alert 1	Toggle	AUX C5 = POSITIVE AUX C6 = POSITIVE	Alert 1 + Lighting 1
Slide/Alert 2	Toggle	AUX C5 = POSITIVE AUX C6 = POSITIVE AUX A1 = POSITIVE Horn Ring = ENABLED	Alert 2 + Lighting 2
Slide/Alert 3	Toggle	AUX C5 = POSITIVE AUX C6 = POSITIVE AUX A1 = POSITIVE AUX A2 = POSITIVE Horn Ring = ENABLED	Alert 3 + Lighting 3
Rotary 0	Toggle	Tones OFF	Alert 0
A1/Rotary 1	Toggle	Horn Ring = ENABLED Primary/Hit-N-Go: WAIL/YELP Secondary/Hit-N-Go: YELP/LOW FREQ YELP	
A2/Rotary 2	Toggle	Horn Ring = ENABLED Primary/Hit-N-Go: YELP/HYPER-YELP 1 Secondary/Hit-N-Go: HYPER-YELP 1/LOW FREQ YELP	
A3/Rotary 3	Toggle	Horn Ring = ENABLED Primary/Hit-N-Go: HI-LO 1/COMMAND ALERT Secondary/Hit-N-Go: HYPER-LO 1/LOW FREQ YELP	
A4	Momentary	Slide/Alert 3 AUX Outs Horn Ring = ENABLED Primary: MECHANICAL MANUAL WAIL 1 Secondary: MECHANICAL MANUAL WAIL 1	Alert 3 + Lighting 3
A5	Momentary	Slide/Alert 3 AUX Outs Primary: AIRHORN 1 Secondary: AIRHORN 2	Alert 3 + Lighting 3
B1	Toggle	AUX B1 = ON	Left Alley
B2	Toggle	AUX B2 = ON	Right Alley
B3	Toggle	AUX B3 = ON	Center TD
B4	Toggle	AUX B4 = ON	Full Scene
B5	Toggle	AUX B5 = ON	Left Corners Scene
B6	Toggle	AUX B6 = ON	Right Corners Scene
B7	Timed	AUX B7 = ON	
B8	Toggle	AUX B8 = ON	
C1	Toggle	AUX C1 = ON	Arrowstik Left Build Fast
C2	Toggle	AUX C1 = ON AUX C2 = ON	Arrowstik Center Build Fast
C3	Toggle	AUX C2 = ON	Arrowstik Right Build Fast
C5	Toggle	AUX C4 = ON	Simultaneous Flash
C4	Toggle	AUX C3 = ON	DIM



Figure 4 - Rotary Control Head Key



Figure 5 - Push Button Control Head Key

Control Head - Menus		
Menu	Access	Functionality
Backlight Level	Push and hold C1 or C3 while in Alert Level 0. C2 will illuminate while menu is active. Release C1, C3.	Press and hold C1 to decrease backlight level. Press and hold C3 to increase backlight level. Press C5 to exit the menu.
RRB Volume	Drive INPUT 5 (Gray) high. Then push and hold C1 or C3 while in Alert Level 0. C2 will illuminate while menu is active. Release C1, C3.	Press and hold C1 to decrease RRB volume. Press and hold C3 to increase RRB volume. Press C5 to exit the menu.
PA Volume	Hold the PTT button on the microphone. Then push and hold C1 or C3 while in Alert Level 0. C2 will illuminate while menu is active. Release C1, C3.	Press and hold C1 to decrease PA volume. Press and hold C3 to increase PA volume. Press C5 to exit the menu.

Discrete Input - Default Functions			
Input	Color	Function	Active
IN 1	ORANGE	HANDS-FREE	POSITIVE
IN 2	PURPLE	CONFIGURABLE	GROUND
IN 3	ORANGE/BLACK	PARK KILL	GROUND
IN 4	PURPLE/BLACK	ALARM	POSITIVE
IN 5	GRAY	RRB	POSITIVE
IN 6	GRAY/BLACK	IGNITION	POSITIVE
IN 7	PINK/WHITE	AUX C7 = GROUND	POSITIVE
IN 8	BROWN	CONFIGURABLE	POSITIVE
IN 9	ORANGE/WHITE	CONFIGURABLE	POSITIVE
IN 10	PURPLE/WHITE	CONFIGURABLE	POSITIVE
IN 11	GRAY/WHITE	CONFIGURABLE	POSITIVE
IN 12	BLUE/WHITE	CONFIGURABLE	POSITIVE
IN 13	GREEN/WHITE	CONFIGURABLE	POSITIVE
IN 14	BROWN/WHITE	CONFIGURABLE	POSITIVE
RRB IN 1	YELLOW	RRB INPUTS	N/A
RRB IN 2	YELLOW/BLACK		N/A
HORN RING	WHITE	HORN RING INPUT	GROUND
HORN RELAY	BLUE	HORN RING TRANSFER RELAY	N/A

## Feature Descriptions:

The information below describes the features of the Z3S(X) Siren system. Many of these features are configurable using the Matrix Configurator. See software manual 920-0731-00 for further information.

*Siren Priority* – Audible siren outputs conform to the following priority order from highest to lowest; PTT/PA, RRB, Airhorn tones, Alarm function, Manual tones, remaining tones (e.g. Wail, Yelp, Hi-Lo).

*Hands-Free* – This mode enables the Scroll functionality, as well as Alert Level 3 lighting, in response to the vehicle's horn input. To enable this mode, apply Positive voltage to the discrete wire input IN 1 (Orange).

*Horn Ring* – This input allows the Z3S siren to respond to the vehicle horn press. See the Wiring Diagram for details. This input is only enabled in Alert Level 2 or above, and when tones are active, by default. When enabled the vehicle's horn input is replaced by siren tones.

*Hit-N-Go* – This mode overrides an active siren tone for eight (8) seconds. It can be enabled by the Horn Ring input.

**Note: the Horn Ring input cannot enable Hit-N-Go mode if the Hands Free mode is active. The specific override tones are outlined in the Control Head - Default Functions table.**

*Scroll* – This function loops through a list of push button inputs and must be configured via software. When active, a defined input will advance to the next available push button, e.g. A1 -> A2 -> A3 -> A1. By default, this input is the short press Horn Ring. If no tone is active, A1 will be selected. A long press Horn Ring will turn on an Airhorn tone. To stop the function loop, press the currently active push button. Note: in Hands Free mode a long press will instead disable the current push button input.

*Scroll On/Off* – This mode is similar to the Scroll mode except that it inserts an OFF state at the end of the push button input list. This mode must also be configured via software.

*Overvoltage Lockout* – This function monitors system supply voltages to prevent speaker damage. Supply voltages greater than 15V will shutoff siren tones per the table below. The siren tones can be turned on again after shutoff by reactivating the input. This will reset the overvoltage timer. See software manual 920-0731-00 for further information.

Supply Voltage	Duration
15 - 16 VDC	15 min.
16 - 17 VDC	10 min.
17 - 18 VDC	5 min.
18+ VDC	0 min.

*LightAlert* – This function produces an audible noise from the Control Head on a periodic basis if any lighting or auxiliary outputs are enabled.

*Sleep* – This mode allows the siren to enter a low power state when the vehicle is turned off. Removing Positive from the Ignition input starts a timer which lasts one (1) hour by default. The Z3S siren enters Sleep mode whenever the timer runs out. Reapplying Positive to the Ignition input will prevent the siren from going to sleep.

*Overcurrent Lockout* – This function monitors tone output currents to prevent siren damage. If a short circuit is detected, the corners of the ArrowStik Indicator on the control head will flash RED momentarily to warn the operator. The tone output will be disabled for 10 seconds before retry.

*Radio Rebroadcast (RRB)* – This mode allows a user to rebroadcast an audio signal over the siren speakers. Siren tones do not operate when this mode is enabled. Connect the audio signal to the RRB 1 and RRB 2 discrete inputs (Yellow and Yellow/Black). Polarity is not an issue. The mode can be enabled by applying Positive to discrete input IN 5 (Gray). The volume of the output can be adjusted using the RRB volume menu. See the Control Head - Menus table for more details.

*Push-To-Talk (PTT)* – Select the momentary button on the side of the microphone to switch the siren outputs to the Public Address (PA) mode. This will override all other active tone outputs until the button is released.

*Public Address (PA)* – This mode allows a user to broadcast their voice over the siren speakers. This takes priority over all other siren tone functions. The mode can be enabled by pushing the PTT button. The volume of the output can be adjusted using the PA volume menu. See the Control Head - Menus table for more details.

*Microphone Lockout* – This function disables the PA mode if the PTT input is held for 30 seconds. This will avoid the situation where the PTT is stuck in the on position for an extended period. To continue using PA mode, release the PTT button and press it again.

*Fuse Indicators* – All fuses are accessible from outside the siren housing. An open fuse is indicated with a RED LED located next to the fuse. In the event of an open fuse, the corners of the ArrowStik Indicator will momentarily flash RED to warn the operator.

**Note: The fuse LED for the Secondary Siren output on a Z3SX system will illuminate GREEN under normal operation.**

*Park Kill* – This function enables the Standby mode. To enable this function, apply Ground to the discrete wire input IN 3 (Orange/Black). When Park Kill is disabled, active tones will remain in Standby. Airhorn tones and the Alarm function are not affected by Standby mode.

*Alarm* – This function will output an Alarm Chirp tone. To enable this function, apply Positive to the discrete wire input IN 4 (Purple/Black). For example, this can be used to alarm the police officer when a temperature sensor on a K-9 unit has reached dangerous levels. The Alarm input will operate even in Sleep Mode.

*Ignition* – This function controls the Sleep Mode of the siren. Apply Positive to the discrete input IN 6 (Gray/Black) to exit Sleep Mode. A USB cable between the siren and a PC running the Matrix Configurator will also exit Sleep Mode.

**Note: One (1) minute after communication with the software is terminated the system will reset.**

*ArrowStik Indicator* – The LEDs located in the upper right corner of the control head indicate the current status of any traffic director on the Matrix network. They are also used to indicate system faults: the far left and right arrows will momentarily flash RED in the presence of a fault. They are also used to display menu information.

*Standby* – This mode disables siren tones and prevents the Matrix network from being in Alert 3. A Control Head tone button that is affected will begin to blink at a steady rate when this mode is enabled. All functions, except siren tones, will resume immediately on exiting Standby mode. A short press will re-enable the tone button once Standby is removed, or a long press will turn the tone off permanently.

*Manual Tones* – This function produces a manual style tone when enabled. A manual tone will ramp up to its maximum frequency and hold until the input is released. When the input is released the tone will ramp down and return to the previous function. If the button is pressed again before the ramp down is completed, the tone will start ramping up again from the current frequency. If another tone is active the Manual Tones will take priority per the Siren Priority.

*Positive* – A voltage applied to an input wire that is 10V or greater.

*Ground* – A voltage applied to an input wire that is 1V or less.

*Alert 0/1/2/3 (Level 0/1/2/3)* – These modes group default functions together for one touch access, e.g. slide switch position. By default, there are three (3) available groups. These groups can be modified. See software manual 920-0731-00 for further information.

*Brownout Condition* – This function allows the Matrix network to recover from an extended low voltage condition. Recovery time is five (5) seconds or less once the Brownout Condition is relieved. The control head will beep three times. Functions operating prior to the Brownout Condition will not automatically resume.

#### Button Input Types:

*Timed* – Active on press; inactive after defined duration or next press

*Toggle* – Active on press; inactive after next press

*Momentary* – Active while held; inactive on release



**Troubleshooting:**

<b>Problem</b>	<b>Possible Cause(s)</b>	<b>Comments / Response</b>
<b>No Power</b>	Power Wiring	Ensure power and ground connections to the Siren are secured. Ensure input voltage does not exceed the range of 10-16 VDC. Remove and reconnect the power wire harness.
	Blown Fuse / Reverse Polarity	Check and replace the fuse(s) feeding the power wire harness if necessary. Verify the correct power wire polarity.
	Ignition Input	The Ignition wire input is required to bring the Siren out of a Sleep mode. Ensure that the Ignition wire is connected properly. Note that the Siren will revert to a Sleep mode after a default 1 hour time period if Ignition is removed. Driving the Ignition wire high again will resume active operation. Connecting the Siren to the Matrix Configurator via USB will keep the network active while the software is active.
<b>No Communication</b>	Connectivity	Ensure that all other Matrix devices are securely connected to the Siren. For example, ensure that the CAT5 cable(s) are fully seated into the RJ45 jacks with positive lock.
<b>No Siren Tones</b>	Park Kill	Shift the vehicle out of park to exit Park Kill. Press the desired tone input to exit Standby.
	Overcurrent Lockout	The corners of the ArrowStik Indicator will flash RED momentarily to warn the operator of a short circuit condition. Check the speaker wiring and condition. Replace as needed.
	Overvoltage Lockout	See Feature Descriptions section for more detail. Monitor the vehicle supply during operation.
	PA/RRB	The PA and RRB function both override normal siren operation. Release the PTT button or remove the signal from the RRB input.
	Defective Speaker(s)	Verify resistance across the speaker(s) in the range of 4Ω - 6Ω. Replace speaker(s) as necessary.
	Siren Temperature	Siren tone outputs shut off at an over temperature threshold. This allows the system to cool, and avoid damage to the components. Once temperatures decrease, the siren tones will resume operation.
	Speaker Wiring	Check speaker harness wiring. Ensure positive lock, proper connections, and continuity. Ensure that tones are heard from within the siren enclosure when active.
<b>Open Siren Fuse</b>	Defective Speaker(s)	Verify resistance across the speaker(s) in the range of 4Ω - 6Ω. Replace speaker(s) as necessary.
	Auxiliary A/B/C Output Overcurrent	See Specifications / Auxiliary Outputs for output type current limits. Ensure that each output type does not exceed its rating.
<b>Siren Tone Quality</b>	Low Supply Voltage	Ensure power and ground connections to the Siren are secured. If an aftermarket power distribution system is installed, ensure that its rated current capacity is sufficient for all downstream loads.
	Speaker Wiring	Check speaker harness wiring. Ensure positive lock, proper connections, and continuity. Ensure that tones are heard from within the siren enclosure when active.
	Speaker Arrangement	Multiple speakers on the same output harness must be installed in parallel. Refer to Wiring Diagram for details.
	Defective Speaker(s)	Verify resistance across the speaker(s) in the range of 4Ω - 6Ω. Replace speaker(s) as necessary.
<b>Premature Speaker Failure</b>	High Supply Voltage	Verify proper operation of the vehicle charging system. Supply voltage in excess of 15V will induce the Overvoltage Lockout.
	Speaker Type	Only 100W speakers are permitted. Contact customer support for a list of approved speakers/speaker ratings.

<b>Problem</b>	<b>Possible Cause(s)</b>	<b>Comments / Response</b>
<b>Auxiliary Output Failure</b>	Output Wiring	Check output harness wiring. Ensure positive lock, proper connections, and continuity.
	Output Load	Verify that the load is not shorted. All outputs are designed to self current limit in case of short circuit. In some cases, this may prevent an open fuse. See Specifications / Auxiliary Outputs for output type current limits. Ensure that each output type does not exceed its rating.
<b>PA Quality</b>	PA Volume	See the Control Head - Menus table for more details.
	Microphone Connection	Check microphone wiring. Ensure positive lock, proper connections, and continuity.
	Defective Microphone	Test the siren with another microphone.
	Microphone Lockout	This function disables the PA mode if the PTT input is held for 30 seconds. This will avoid the situation where the PTT is stuck in the on position for an extended period. To continue using PA mode, release the PTT button and press it again.
	Microphone Type	Contact customer support for a list of approved microphones.
<b>RRB Quality</b>	RRB Volume	See the Control Head - Menus table for more details.
	Audio Signal Connection	Check microphone wiring. Ensure positive lock, proper connections, and continuity.
	Audio Signal Amplitude	Ensure that the audio source volume is high enough. Turn up the source volume as necessary.
<b>Control Head</b>	Connectivity	Ensure that the CAT5 cable from the control head is fully seated into the RJ45 jack on both ends. Note that the control head jack is labeled 'KEY w/ PA'. Replace the cable if necessary.
	Sleep mode	Ensure that the Ignition wire is connected properly, and Positive is applied.
	Fault LEDs	The LEDs located in the upper right corner of the control head are used to indicate system faults: the far left and right arrows will momentarily flash RED in the presence of a fault.
	Park Kill	Buttons will flash slowly if the associated functions are on Standby. Shift the vehicle out of park to exit Park Kill. Then press the desired tone input to exit Standby.
	Configuration Error	Connect the siren to the Matrix Configurator and reload the desired system configuration.
<b>Unexpected Operation (Misc)</b>	Scroll	Verify that the Horn Ring input is not inadvertently triggered. This could cause the system to enter Scroll mode.
	Configuration Error	Connect the siren to the Matrix Configurator and reload the desired system configuration.

## Replacement Parts and Accessories:

All replacement parts and accessories pertaining to the product will be placed in a chart with their description and part numbers. Below is an example of a Replacement/Accessories chart.

Description	Part No.
Z3S PUSH BUTTON CONTROL HEAD	CZPCH
Z3S ROTARY CONTROL HEAD	CZRCH
Z3S HARNESS	CZZ3SH
Z3S LEGEND SET	CZZ3SL
Z3S SIREN MICROPHONE	CZZ3SMIC

## Warranty:

### Manufacturer Limited Warranty Policy:

Manufacturer warrants that on the date of purchase this product will conform to Manufacturer's specifications for this product (which are available from the Manufacturer upon request). This Limited Warranty extends for Sixty (60) months from the date of purchase.

**DAMAGE TO PARTS OR PRODUCTS RESULTING FROM TAMPERING, ACCIDENT, ABUSE, MISUSE, NEGLIGENCE, UNAPPROVED MODIFICATIONS, FIRE OR OTHER HAZARD; IMPROPER INSTALLATION OR OPERATION; OR NOT BEING MAINTAINED IN ACCORDANCE WITH THE MAINTENANCE PROCEDURES SET FORTH IN MANUFACTURER'S INSTALLATION AND OPERATING INSTRUCTIONS VOIDS THIS LIMITED WARRANTY.**

### Exclusion of Other Warranties:

MANUFACTURER MAKES NO OTHER WARRANTIES, EXPRESS OR IMPLIED. THE IMPLIED WARRANTIES FOR MERCHANTABILITY, QUALITY OR FITNESS FOR A PARTICULAR PURPOSE, OR ARISING FROM A COURSE OF DEALING, USAGE OR TRADE PRACTICE ARE HEREBY EXCLUDED AND SHALL NOT APPLY TO THE PRODUCT AND ARE HEREBY DISCLAIMED, EXCEPT TO THE EXTENT PROHIBITED BY APPLICABLE LAW. ORAL STATEMENTS OR REPRESENTATIONS ABOUT THE PRODUCT DO NOT CONSTITUTE WARRANTIES.

### Remedies and Limitation of Liability:

MANUFACTURER'S SOLE LIABILITY AND BUYER'S EXCLUSIVE REMEDY IN CONTRACT, TORT (INCLUDING NEGLIGENCE), OR UNDER ANY OTHER THEORY AGAINST MANUFACTURER REGARDING THE PRODUCT AND ITS USE SHALL BE, AT MANUFACTURER'S DISCRETION, THE REPLACEMENT OR REPAIR OF THE PRODUCT, OR THE REFUND OF THE PURCHASE PRICE PAID BY BUYER FOR NON-CONFORMING PRODUCT. IN NO EVENT SHALL MANUFACTURER'S LIABILITY ARISING OUT OF THIS LIMITED WARRANTY OR ANY OTHER CLAIM RELATED TO THE MANUFACTURER'S PRODUCTS EXCEED THE AMOUNT PAID FOR THE PRODUCT BY BUYER AT THE TIME OF THE ORIGINAL PURCHASE. IN NO EVENT SHALL MANUFACTURER BE LIABLE FOR LOST PROFITS, THE COST OF SUBSTITUTE EQUIPMENT OR LABOR, PROPERTY DAMAGE, OR OTHER SPECIAL, CONSEQUENTIAL, OR INCIDENTAL DAMAGES BASED UPON ANY CLAIM FOR BREACH OF CONTRACT, IMPROPER INSTALLATION, NEGLIGENCE, OR OTHER CLAIM, EVEN IF MANUFACTURER OR A MANUFACTURER'S REPRESENTATIVE HAS BEEN ADVISED OF THE POSSIBILITY OF SUCH DAMAGES. MANUFACTURER SHALL HAVE NO FURTHER OBLIGATION OR LIABILITY WITH RESPECT TO THE PRODUCT OR ITS SALE, OPERATION AND USE, AND MANUFACTURER NEITHER ASSUMES NOR AUTHORIZES THE ASSUMPTION OF ANY OTHER OBLIGATION OR LIABILITY IN CONNECTION WITH SUCH PRODUCT.

This Limited Warranty defines specific legal rights. You may have other legal rights which vary from jurisdiction to jurisdiction. Some jurisdictions do not allow the exclusion or limitation of incidental or consequential damages.

### Product Returns:

If a product must be returned for repair or replacement\*, please contact our factory to obtain a Return Goods Authorization Number (RGA number) before you ship the product to Code 3®, Inc. Write the RGA number clearly on the package near the mailing label. Be sure you use sufficient packing materials to avoid damage to the product being returned while in transit.

\*Code 3®, Inc. reserves the right to repair or replace at its discretion. Code 3®, Inc. assumes no responsibility or liability for expenses incurred for the removal and /or reinstallation of products requiring service and/or repair.; nor for the packaging, handling, and shipping; nor for the handling of products returned to sender after the service has been rendered.



10986 North Warson Road  
St. Louis, MO 63114

**Technical Service**  
(314) 996-2800

c3\_tech\_support@code3esg.com  
www.code3esg.com

An ECCO SAFETY GROUP™ Brand  
www.eccosafetygroup.com